



100 WATT Universal Input MEDICAL AC/DC Power Supplies



FEATURES

- **Universal Input Range**
- **Operating Temperature Range:**
-25° to +80° C (with derating)
- **Open Frame Package**
2.00" X 3.00" X 1.16"
Options: Chassis Mount
Enclosed
Din Rail
- **High Efficiency: To 92%**
- **Active Power Factor Correction**
- **4000 Vac Input/Output**
2MOPP Isolation
Class I and Class II Protection
- **Built-In EMI Class A Filter**
- **Low Leakage Current under 75µA**
- **Medical Safety Approvals**
Including: UL, CE and ANSI/AAMI
ES60601-1, EN60601-1, and
IEC60601-1 3rd Edition
- **RoHS Compliant to 2011/65/EU**

MUI100 Series

Specifications - All specifications are typical at nominal input, full load and 25° C.

INPUT

Voltage Range.....	AC Input.....	85 to 264VAC
	DC Input.....	120 to 370VDC
Input Frequency.....	AC Input.....	47 to 63Hz
Input Current.....	115VAC and Full Load.....	1.15 A
	230VAC and Full Load.....	0.55 A
No Load Input Power.....	230VAC.....	0.3 Watts
Leakage Current.....	264VAC.....	75µA
Power Factor.....		0.95
Start up time.....		1000ms
Rise time.....		20ms
Hold up time.....	115VAC and Full Load.....	16ms
Input inrush current.....	230VAC.....	60A
Input protection.....	Internal fuse inline and neutral	T3,15A/250VAC

OUTPUT

Output Power.....	Open frame.....	100Watts
Initial set Voltage Accuracy.....	230VAC and Full Load.....	±1.0%
Line Regulation.....	Low Line to High Line at Full Load.....	±0.2%
Load Regulation.....	No Load to Full Load.....	±0.5%
	10% Load to 90% Load.....	±0.4%
Voltage Adjustability.....		±10%
Minimum Load.....		0%
Ripple and Noise.....	Measured by 20MHz band width	
	With a 10µF/25V 1206 X7R MLCC.....	12Vout... 120mVp-p
	With a 10µF/25V 1206 X7R MLCC.....	15Vout... 150mVp-p
	With a 1µF/50V 1206 X7R MLCC.....	24Vout... 160mVp-p
	With a 1µF/50V 1206 X7R MLCC.....	28Vout... 180mVp-p
	With a 1µF/50V 1206 X7R MLCC.....	36Vout... 190mVp-p
	With a 0.1µF/100V 1206 X7R MLCC.....	48Vout... 340mVp-p
Temperature Coefficient.....		±0.2%°C
Transient Response.....	Load step from 50-75% change at 2.5A/µs...	Peak deviation..... 3%Vout
		Recovery time..... 500µs
Over Voltage Protection.....	% of Vout(nom); Latch mode.....	135%
Over Load Protection.....	% of Iout rated; Hiccup mode.....	150%
		12Vout, 15Vout
Short Circuit Protection.....		Continuous, automatic recovery

Additional specifications on next page.



GENERAL

Efficiency.....See table
 Isolation Voltage 1 minute (2MOPP insulation)... Input to Output.....4000Vac
 Input (Output) to F.G. .. 1500Vac
 Isolation Resistance...500Vdc.....0.1GΩ
 Switching Frequency.60kHz
 Approvals and Standard.....ANSI/AAMI, ES60601-1, IEC6060-1, EN60601-1
MUIO.....156g (5.50oz)
 WeightMUIT.....194g (6.84oz)
MUI.....210g (7.41oz)
MUID.....232g (8.18oz)
 MTBF.. MIL-HDBK-217F Ta25°C, Full load.....7.903 x 10⁵ hrs

ENVIRONMENTAL

Operating Ambient Temperaturewith derating.....-25°C to +80°C
 Storage Temperature Range.....-40°C to +85°C
 Operating Altitude.....5000m
 Thermal Shock.....MIL-STD-810F
 Shock.....IEC68-2-27
 Vibration.....IEC68-2-6
 Relative Humidity.....Non-condensing.....5% to 95% RH

EMC

EMI.....EN55011, EN55022 and FCC Part 18.....Class A, Class B
 Harmonic Currents.....EN61000-3-2.....Full Load.....Class A and D
 Voltage Flicker.....EN61000-3-3.....
 ESD.....EN61000-4-2..... Air ±8KV and Contact ±6KV..... Perf. Criteria A
 Radiated Immunity.....EN61000-4-3..... 20 V/m..... Perf. Criteria A
 Fast Transient.....EN61000-4-4..... ±2KV..... Perf. Criteria A
 Surge.....EN61000-4-5..... DM ±1KV and CM ±2KV..... Perf. Criteria A
 Conducted Immunity.....EN61000-4-6..... 20Vr.m.s. Perf. Criteria A
30%500mSPerf. Criteria A
60%100mSPerf. Criteria A
 230Vac 50Hz>95%10mSPerf. Criteria A
>95% ..5000mSPerf. Criteria B
30%500mSPerf. Criteria A
60%100mSPerf. Criteria A
 100Vac 50Hz>95%10mSPerf. Criteria A
>95% ..5000mSPerf. Criteria B

All specifications are typical at 230Vac input, full load, and 25 °C unless otherwise noted.

SELECTION GUIDE					
Input Range (Vac)	Output Voltage (Vdc)	Output Current @ Natural Convection 50°C Ta (A)	Input Power @ No Load (W)	Efficiency (%)	Model Number*
85-264	12	8.34	0.3	91	MUI100-S12
85-264	15	6.67	0.3	92	MUI100-S15
85-264	24	4.17	0.3	92	MUI100-S24
85-264	28	3.58	0.3	92	MUI100-S28
85-264	36	2.78	0.3	91	MUI100-S36
85-264	48	2.09	0.3	91	MUI100-S48

* MUIO: Open Type
 MUIT: Chassis Type
 MUID: Din Rail
 MUI: Enclosed (Standard)

Mechanical specifications on next page.



POLYTRON DEVICES, Inc.

P.O. Box 398, Paterson, New Jersey 07544 U.S.A.
 Tel: (973)345-5885 FAX: (973)345-1264 • Email: sales@polytrondevices.com • www.polytrondevices.com

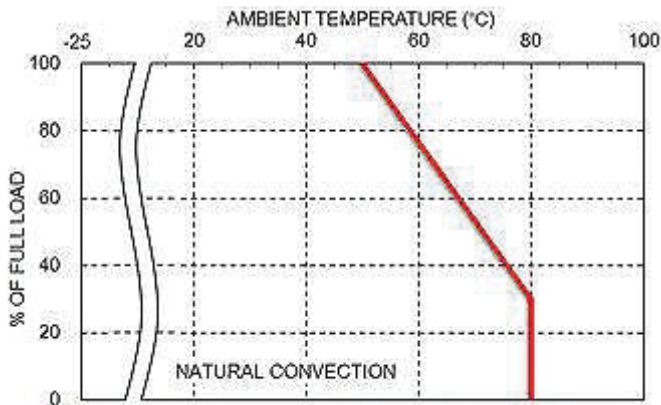

Derating Curve vs. Ambient Temperature

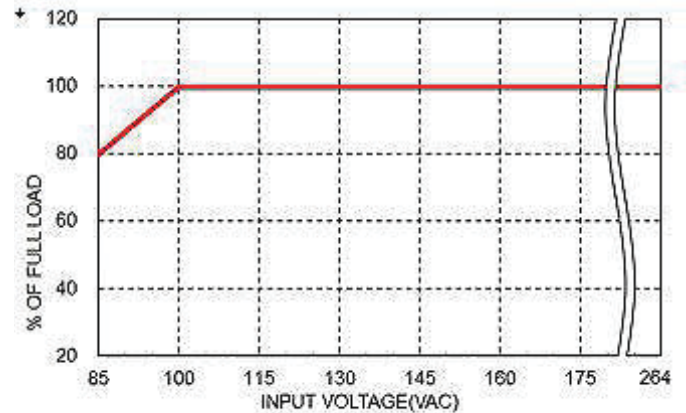

Derating Curve vs. Input Voltage

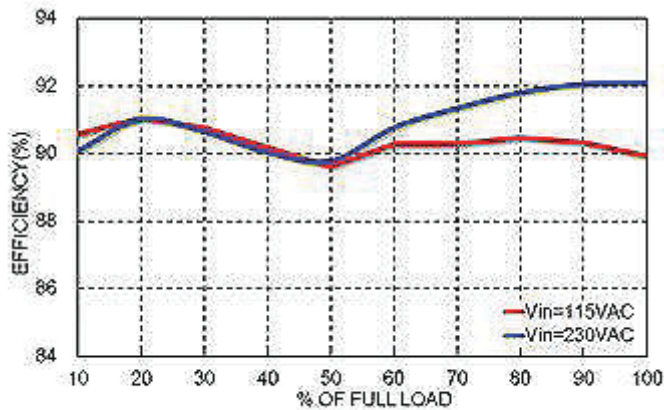

Efficiency vs. Output Load

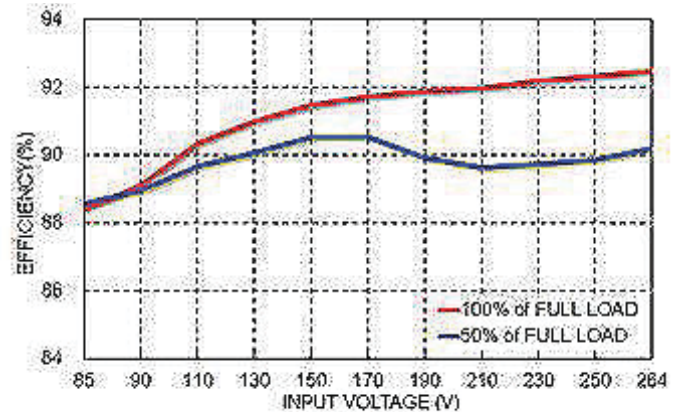

Efficiency vs. Input Voltage

MUI100 OpenType Mechanical Drawing

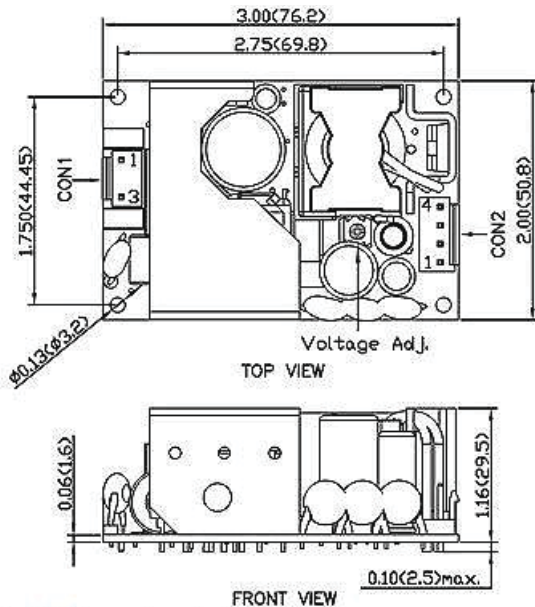

1. All dimensions in inch (mm)
2. Tolerance : x.xx±0.02 (x.x±0.5) x.xxx±0.01 (x.xx±0.25)
3. M3×0.5 screw locked torque MAX 5Kgf.cm/0.49N.m

CON1 - Input Connector	
PIN 1	Line
PIN 3	Neutral
Mates with	
JST housing : VHR-3N	
JST crimp terminals : SVH-21T-P1.1	
Mounting holes marked with ⊕	
must be connected to safety earth for CLASS 1 application	
CON2 - Output Connector	
PIN 1, 2	-Vout
PIN 3, 4	+Vout
Mates with	
JST housing : VHR-4N	
JST crimp terminals : SVH-21T-P1.1	

Additional mechanical specifications on next page.



POLYTRON DEVICES, Inc.

P.O. Box 398, Paterson, New Jersey 07544 U.S.A.
 Tel: (973)345-5885 FAX: (973)345-1264 • Email: sales@polytrondevices.com • www.polytrondevices.com

MUI100 ChassisType Mechanical Drawing

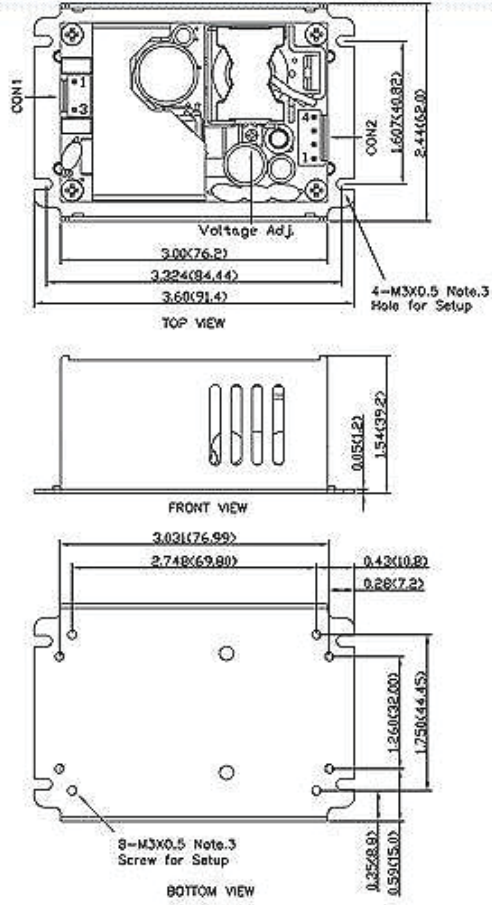

MUI100 Enclosed Type Mechanical Drawing

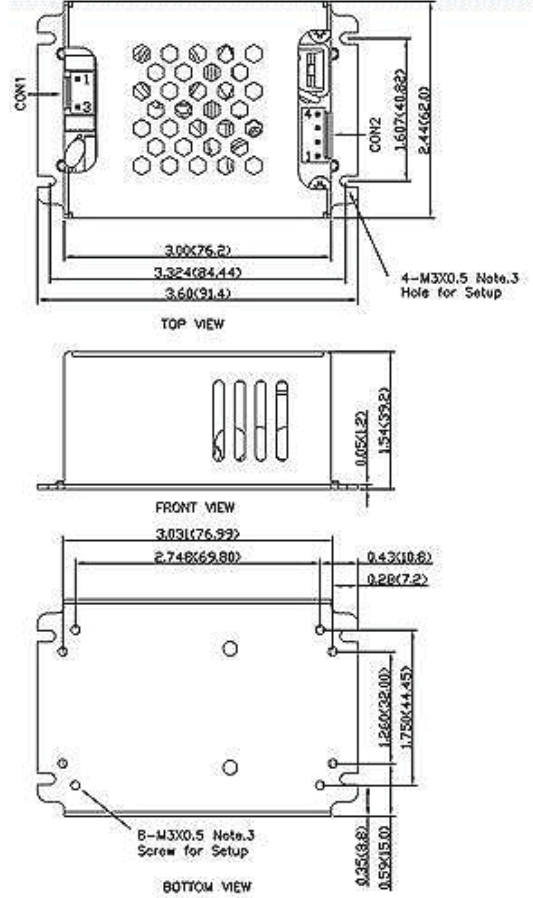

MUI100 Din Rail Type Mechanical Drawing

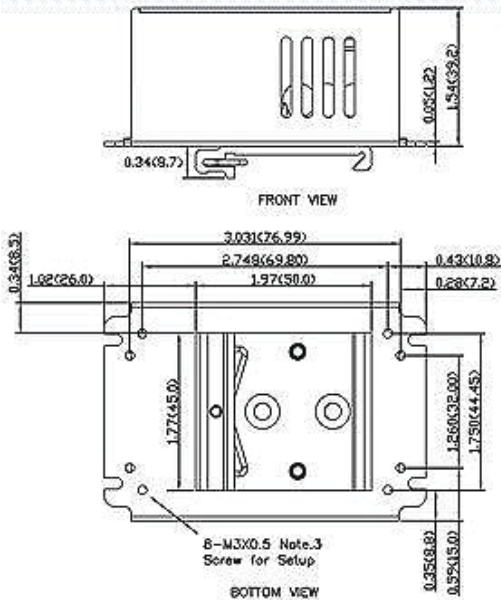

POLYTRON DEVICES, Inc.

P.O. Box 398, Paterson, New Jersey 07544 U.S.A.

Tel: (973)345-5885 FAX: (973)345-1264 • Email: sales@polytrondevices.com • www.polytrondevices.com